

INSTALLATION INSTRUCTIONS

1. CONSTRUCT FRAME WORK
 - BEFORE INSTALLING DRYWALL, A FRAMED OPENING MUST BE CONSTRUCTED TO SUPPORT DIFFUSER FRAME.
2. ATTACH MOUNTING CLIPS
 - MOUNTING CLIPS ARE SHIPPED LOOSE FOR FIELD ATTACHMENT TO DIFFUSER FRAME.
 - SLIDE MOUNTING CLIPS INTO BOSS OF EACH DIFFUSER FRAME RAIL
 - MOUNTING CLIPS SHOULD BE POSITIONED AT A MAXIMUM OF 10" INTERVALS ALONG THE DIFFUSER FRAME.
3. ATTACH DIFFUSER FRAME TO FRAMING
 - SET THE DIFFUSER FRAME INTO THE FRAMED OPENING AND SECURE THE MOUNTING CLIPS TO THE FRAMEWORK WITH FLATHEAD SCREWS.
4. INSTALL DRYWALL
 - SLIDE THE DRYWALL TIGHTLY BETWEEN THE MOUNTING CLIPS AND THE DIFFUSER FRAME FLANGE. FOR EASE OF INSTALLATION, INSERT THE TAPERED EDGE OF THE DRYWALL INTO THIS OPENING. FOR THE BEST FIT, SLIDE THE EDGE OF THE DRYWALL ALL THE WAY TO THE VERTICAL LEG OF THE DIFFUSER FRAME.
 - EVERY 12" AND BETWEEN THE MOUNTING CLIPS, ATTACH SCREWS JUST BESIDE THE DIFFUSER FRAME FLANGE, THROUGH THE DRYWALL, AND INTO THE FRAMING MEMBER.
5. FINISH THE SURFACE.
 - CLEAN THE DIFFUSER FRAME FLANGE TO REMOVE ANY OILS OR RESIDUE.
 - APPLY A JOINT COMPOUND BONDING AGENT TO THE DIFFUSER FRAME FLANGE AND ALLOW TO DRY.
 - APPLY FIRST COAT OF JOINT COMPOUND ONTO THE DIFFUSER FRAME FLANGE AND ONTO DRYWALL THREE INCHES
 - EMBED A 4" WIDE MESH TAPE INTO THIS FIRST COAT. THE TAPE SHOULD COVER THE FLANGE, BUT NOT EXTEND OVER THE RAISED LIP OF THE RAIL.
 - APPLY A SECOND COAT OF JOINT COMPOUND OVER THE TAPE AND SMOOTH.
 - AFTER JOINT COMPOUND HAS DRIED, APPLY TWO COATS OF A STANDARD FINISHING COMPOUND AND LET DRY. SAND, SMOOTH, PRIME, AND PAINT AS SCHEDULED.

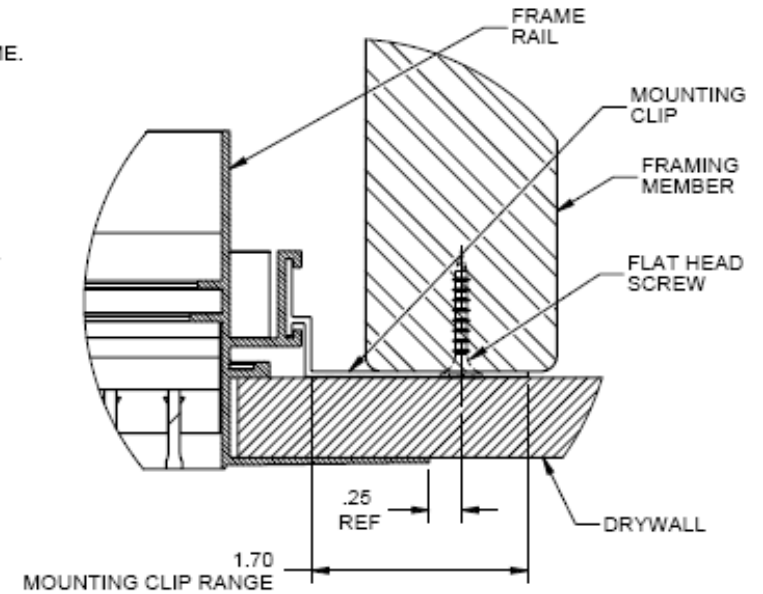

DETAIL M
SCALE 2 : 3

